

# Simulation of Hobbing for Analysis of Cutting Edge Failure due to Chip Crush

Masaharu Komori, Masaoki Sumi and Aizoh Kubo

## Management Summary

There are great advantages in dry hobbing, not only for friendliness toward the environment, but also for increasing productivity and for decreasing manufacturing cost. Dry hobbing, however, often causes failures in hob cutting edges or problems with the surface quality of gear tooth flanks. These difficulties are not present when hobbing with cutting oil. Pinching and crushing of generated chips between the hob cutting edge and the work gear tooth flank is considered a major cause of those problems.

In this report, a hobbing simulation program is developed to clarify the clearance between hob cutting edge and work gear tooth flank and the movement of generated chips on rake surfaces. The simulation explains the mechanism of chip crush and cutting edge failures, and a method to evaluate the probability of chipping on a hob's cutting edge by simulation is proposed.

## Introduction

Dry hobbing is more environmentally friendly than the conventional method, which uses cutting oil (wet hobbing). Dry hobbing has great advantages in increasing productivity and decreasing manufacturing cost as well (Refs. 1–2). Dry hobbing, however, often causes problems, such as chipping of the hob cutting edge or creating of coarse tooth flanks on manufactured gears. These problems are not present in wet hobbing. The pinching and crushing of generated chips between the hob cutting edge and the work gear tooth flank is considered to be a major cause of the problems.

Three types of chip crush between hob cutting edge and work gear tooth flank are possible: (1) crush during generation of chip, (2) crush of chip flying after its generation, (3) crush of chip stuck on hob tooth after a rotation of hob (Ref. 3). Item (2) can be solved by equipping hobbing machines with air blowers. The same remedy and/or selecting of adequate coating and material of hob somewhat improves item (3). But the remedy for item (1) has not been clarified because of the complicated mechanism of hobbing and chip generation.

In this report, a calculating method for the trace of each hob cutting edge relative to the work gear is developed to simulate the clearance between hob cutting edge and work gear tooth flank. Using this simulation, the mechanism of chip crush is clarified and the method to evaluate the probability of chip crush between hob cutting edges and tooth flank is proposed.

## Observation of Dry Cut Hob Failure and Generated Chips

Figure 1 shows a typical chipping failure of a hob cutting edge observed when a right-hand helical gear (module 2.75, pressure angle 20 degrees, number of teeth 62, helix angle 30 degrees and addendum modification factor  $-0.6$ ) is dry cut by a right-hand carbide hob (four threads and outer diameter 100 mm) under climb cutting (2.5 mm/rev.). Chips generated by the hobbing can be classified into types of shape, as shown in Figure 2. The fact that the types of generated chips have the same form suggests the existence of a definite mechanism for chip formation.

Figure 3 shows some examples of chips: Chips

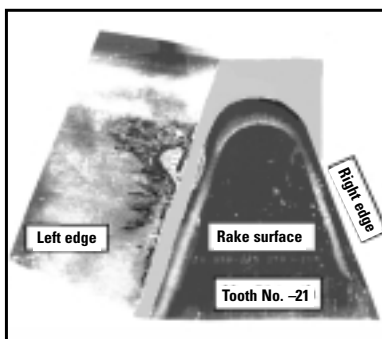

Figure 1—Typical example of chipping failure of cutting edge of carbide hob under dry cutting (example 1).



Figure 2—Classification of dry hobbled chips and their form groups.

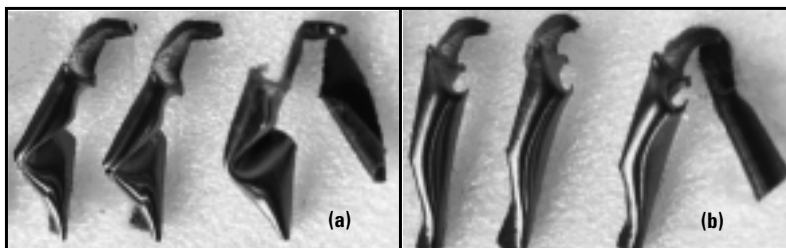

Figure 3—Bent or crushed chips observed under dry cutting: (a)—chips bent after the formation; (b)—same kind of chips as that of (a), but not bent after their formation.

on the right side in (a) and (b) show the originally generated shape. The others are parts of the original chips that separated during this observation. Chips in (a) resemble those in (b) in size and in shape, but each chip in (a) is bent. It is thought that the chips in (a) are pinched and crushed between hob cutting edges and work gear tooth flanks. Many examples of such bent chips are found in the pile of chips to be discarded. That means chip crush does not occur by accident, but some repeating definite mechanism of chip crush must exist in the hobbing process.

Each chip in Figure 4 is cut partly on the surface at the same position. Those chips are also considered to be crushed between the hob cutting edge and the work gear tooth flank during the hobbing process.

Chips in Figure 5(a) are the same as those in 5(b), but there is a difference in the right edge of the chip. The chip part in (b) is considered to be cut after its generation. Temper color is observed on that cut section. That suggests chip crush occurred under high temperature condition, i.e. as soon as the chip was generated.

Figure 6 shows a chip stuck on a hob tooth's rake surface, observed when the hobbing machine is retract-stopped in an emergency during cutting. The combination of hob material and work gear material in this case makes that chip easily stick on the rake surface. Figure 6 shows therefore a status of generation of chip on the rake surface during hobbing (Refs. 4–5). Some part of the chip is outside of the hob's rake surface. That suggests some part of the chip can be intruded into the clearance between hob cutting edge and work gear tooth flank. A hob cutting edge can be damaged if a large chip, as shown in (a), is crushed. When a small and thin chip, as shown in (b), is crushed, a part of the chip scratches the work gear tooth flank or is inlaid on the cut surface and the quality of the manufactured gear becomes a problem.

Those facts clarify that there is a steady mechanism causing chip crush between hob cutting edge and work gear tooth flank. Chipping of the hob cutting edge in Figure 1 is therefore probably caused by chip crush.

#### Calculation Method of Chip Formation and Clearance

To prevent chip crush, it is necessary to evaluate the size, shape and movement of chips on or over a hob tooth's rake surface and the condition of clearance between hob cutting edge and work gear tooth flank. A simulation method for the

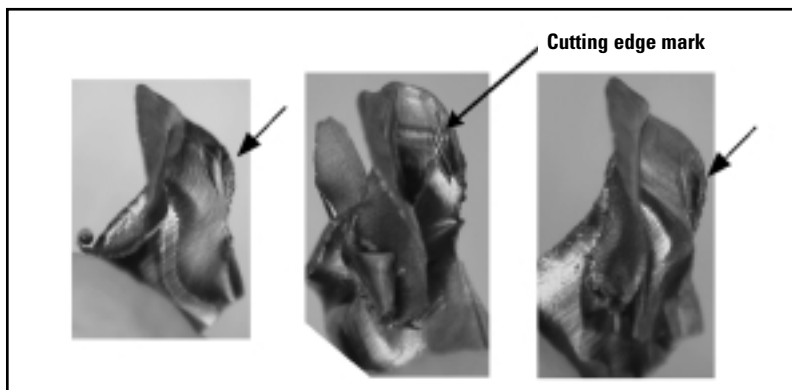

Figure 4—Cutting edge marks found on the same position of chips, observed under dry cutting.

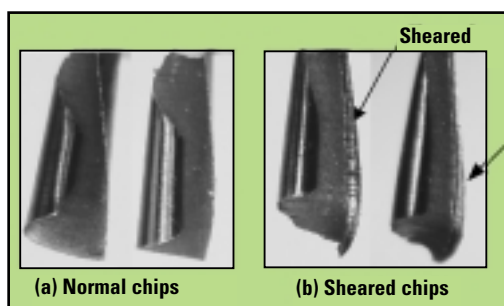

Figure 5—Shearing of chips after their formation, found among dry cut chips (compare with those found in the smallest chip group in right lower section of Figure 2).

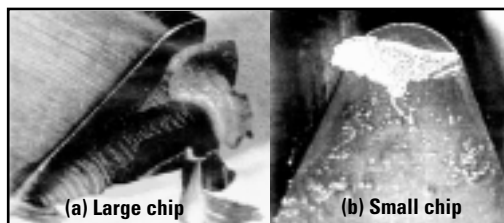

Figure 6—Chips observed on rake surface of hob tooth after emergency retract stop. This is supposed to express the status during cutting.

hobbing status is proposed by Terashima and Ueno (Ref. 6) and others (Refs. 7–10). The expression of the simulation results has been limited to the cutting depth by the hob teeth. It is difficult to understand the changing state of clearance between hob cutting edge and work gear tooth flank by this expression. Evaluation of the probability of chip crush is therefore almost impossible.

**Basic calculation of trace of a point on cutting edge.** The number given to each hob tooth is defined as shown in Figure 7. The hob tooth that generates the center of the work gear's tooth groove is called tooth No. 0, those acting before tooth No. 0 have a minus sign, and those acting after have a plus sign. Here, the side cutting edge located on the left side of the hob tooth, as seen in Figure 1, is called the left edge and the side edge on the right side is called the right edge.

#### Dr. Masaharu Komori

is an associate professor involved in research and education in the precision engineering department of Kyoto University, located in Kyoto, Japan. He has studied and specialized in load carrying capacity, vibration, simulation and troubleshooting of cylindrical gears and hypoid/bevel gears, as well as gear metrology and three-dimensional measurement.

#### Dr. Masaoki Sumi

is a consultant with more than 30 years of experience as an engineer at gear machine tool manufacturer Kashifuji Works Ltd. of Kyoto, Japan. Sumi's work experience includes hobbing of cylindrical gears.

#### Dr. Aizoh Kubo

is a professor performing research and education in Kyoto University's precision engineering department. He has more than 30 years of experience researching gears at the university, including specialization in load carrying capacity, vibration, simulation and troubleshooting of cylindrical gears and hypoid/bevel gears, and gear metrology.

# Simulation of Hobbing for Analysis of Cutting Edge Failure due to Chip Crush

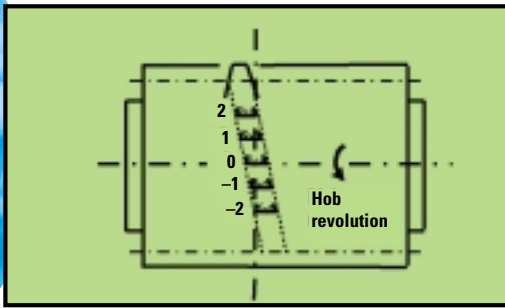

Figure 7—Definition of number given to each hob tooth.

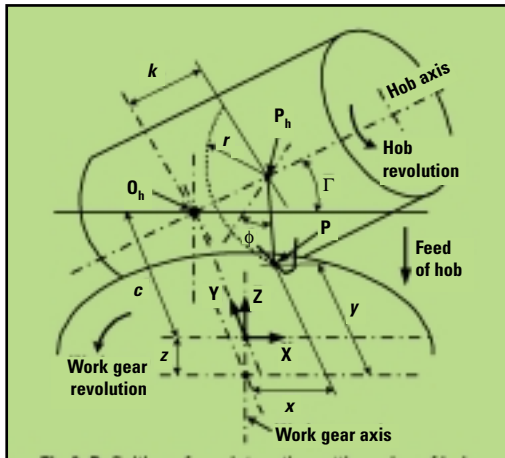

Figure 8—Definition of a point on a hob tooth's cutting edge expressed via hob coordinates and space coordinates.

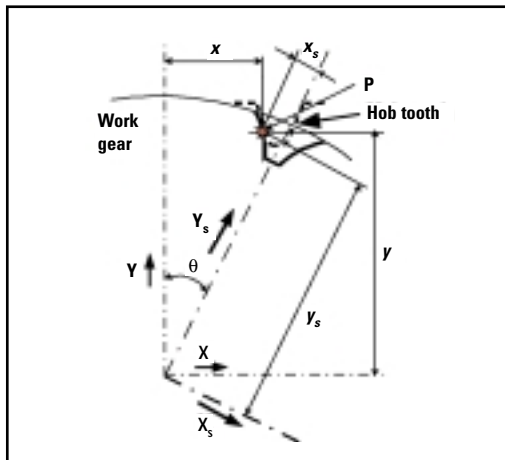

Figure 9—Relationship between gear coordinates  $\{X_s, Y_s, Z_s\}$  and space coordinates  $\{X, Y, Z\}$ . (Axis  $Z_s$  is the same as axis  $Z$ .)

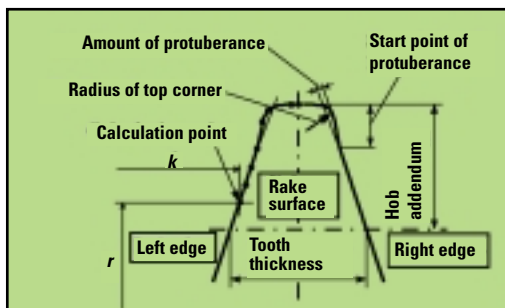

Figure 10—Profile and calculation point on cutting edge of hob tooth.

Figure 8 shows the state of cutting of a right-hand helical gear by a right-hand hob under conventional feed. Point  $O_h$  means the point corresponding to the middle point on the cutting edge of tooth No. 0, but on the hob axis. Point  $P_h$  corresponds to that for arbitrary object point  $P$  on the cutting edge of the hob tooth. Rotation angle  $\phi$  of  $P$  is defined so that the angle is 0 degrees, when line  $PP_h$  is parallel to the side of the work gear. Point  $P$  on the hob cutting edge can be expressed by hob coordinates  $\{k, r, \phi\}$ , where  $k$  is axial distance from  $O_h$  to  $P_h$  and  $r$  is radius.

Space coordinates  $\{X, Y, Z\}$  are set as shown in Figure 8 so the crossing point of the work gear axis and the gear side is its origin. Axis  $Y$  is set normal to the trace of  $O_h$ . A point on these coordinates is expressed by  $\{x, y, z\}$ . A point  $\{k, r, \phi\}$  on the hob coordinates is then converted into space coordinates  $\{x, y, z\}$  as follows (Refs. 7–8):

$$x = k \cos \Gamma - r \sin \phi \sin \Gamma \quad (1)$$

$$y = c - r \cos \phi \quad (2)$$

$$z = k \sin \Gamma + r \sin \phi \cos \Gamma \quad (3)$$

$\Gamma$  means hob set angle, which is defined here by inclination of the hob axis relative to the plane normal to the gear axis.  $c$  shows the center distance of the hob and work gear. The trace of point on the hob's cutting edge during hobbing can be expressed by space coordinates  $\{x, y, z\}$ , by calculating its movement according to hob rotation and feed by Equations 1, 2 and 3.

Gear coordinates  $\{X_s, Y_s, Z_s\}$  are set as shown in Figure 9 in order to calculate the trace of a point on the hob cutting edge relative to the work gear whose origin is the same as that of the space coordinates, and each axis is fixed to the work gear. That is, axis  $Z_s$  is the same as axis  $Z$ , but axis  $X_s$  and  $Y_s$  rotate according to work gear rotation. The position of  $X_s$  and  $Y_s$  becomes the same as that of  $X$  and  $Y$  when the rotation angle for the middle point on hob tooth No. 0's cutting edge is  $0^\circ$ . The rotation angle  $\theta$  of the work gear is expressed as follows:

$$\theta = (\omega + \phi) R_r \quad (4)$$

$\omega$  means hob rotation angle, that is the angle from the middle point on hob tooth No. 0's cutting edge to a definite object point  $P$  on the hob tooth cutting edge along the hob thread.  $R_r$  is the ratio of work gear revolution to hob revolution. Space coordinates are converted into gear coordinates by the following equations:

$$x_s = x \cos \theta - y \sin \theta \quad (5)$$

$$y_s = x \sin \theta + y \cos \theta \quad (6)$$

$$z_s = z \quad (7)$$

**Procedure to calculate traces of cutting edges.** The shape of a hob cutting edge including protuberance is expressed point by point, as shown in Figure 10. The trace of a point on the cutting edge relative to the work gear during cutting can be obtained by calculating the point's movement due to hob rotation and feed and work gear rotation. The trace of a hob cutting edge can be expressed by traces of point groups on the cutting edge.

Figure 11 shows the procedure to calculate the trace of a hob cutting edge. In step (2), fundamental quantities—such as center distance, hob set angle, range of acting hob tooth and axial cutting range of work gear during a hob rotation—are calculated. The tooth groove shape formed before the last revolution of the work gear is calculated in step (3). That shape is formed by traces of all cutting edges acting in that process. For a definite hob cutting edge, the trace of the previously acting hob cutting edge and that of the object cutting edge are calculated in step (5) and (6). This procedure is repeated for each hob tooth's cutting edge.

**Evaluation of probability of chip crush.** Cutting of the gear shown in Table 1(a) by the hob in Table 1(b) under the cutting conditions in Table 1(c) is provided as an example. Center distance is 98.975 mm, hob set angle is 16.23 degrees, acting hob cutting edge is from tooth No. -26 to tooth No. 10, and work gear axial cutting range during a hob rotation is 28 mm (Ref. 7).

Figure 12(a) shows a work gear cut by climb hobbing schematically, where the work gear is set in the front and the hob is behind, and it is observed from a viewpoint below the work gear. A straight tooth groove like that of a spur gear is shown in Figure 12 to make understanding easy even though the sample gear is helical and the actual groove exists in helix form. The trace of the hob cutting edge is here proposed to be expressed on each normal-to-gear-axis slice shown in Figure 12(b). The definition of viewpoint and slices used in this expression of the simulation result are the same for helical and spur gears.

Figure 13 shows the result of traces on the slices at  $z_s = 18$  mm and 15 mm that are normal to the work gear axis. A broken curve shows the tooth groove shape formed before one revolution

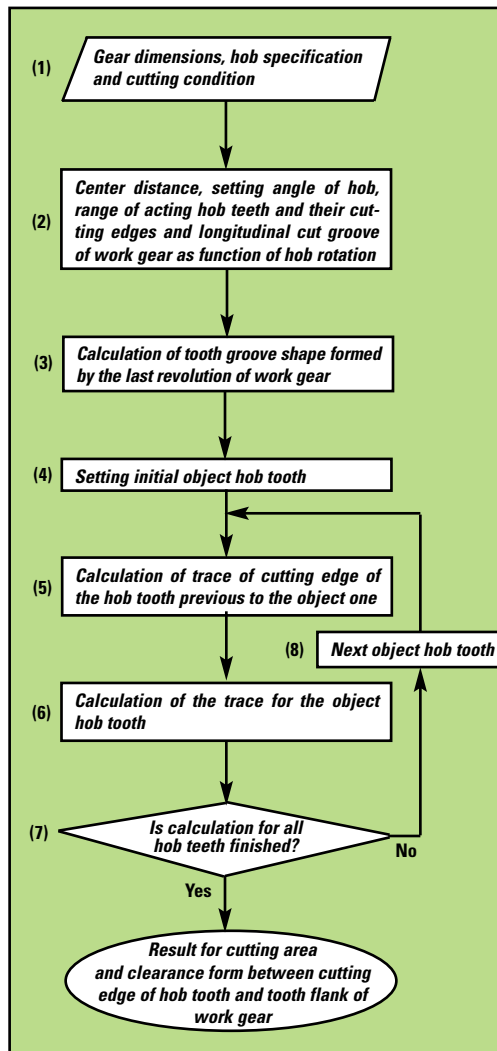

Figure 11—Flow chart for calculating the trace of a hob's cutting edge.

Table 1—Sample Specifications of Gear, Hob and Cutting Conditions.				
(a) Specifications of Gear		(b) Specifications of Hob		(c) Cutting conditions
Module $m$	2.5	Outside diameter	85 mm	Feed of table revolution 4 mm/rev.
Pressure angle $\alpha$	20°	Number of threads $z_1$	2 RH	Direction of feed Climb
Number of teeth $z$	45	Lead angle	3° 46'	Hob set angle $\Gamma$ 16.23°
Helix angle $\beta$	20° RH	Number of gashes $G_n$	16	
Cutting depth	5.875 mm	Amount of protuberance	0.05 mm	
Addendum modification factor $x$	0	Radius of top corner	0.85 mm	
Outside diameter $d_o$	124.70 mm			

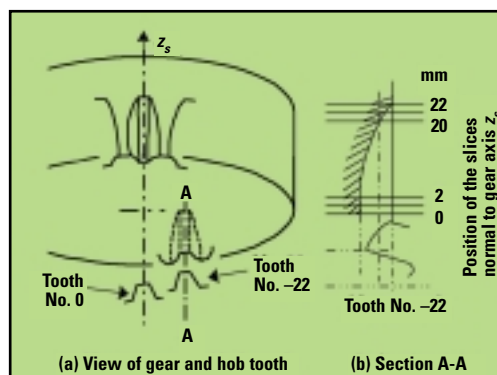

Figure 12—Definition of slices normal to gear axis.

# Simulation of Hobbing for Analysis of Cutting Edge Failure due to Chip Crush

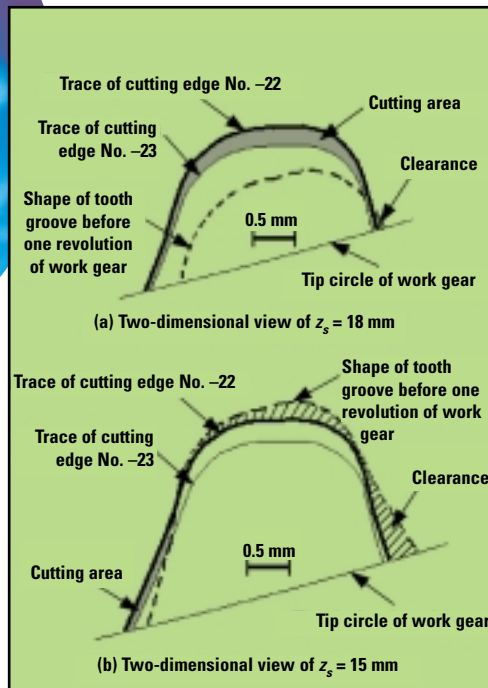

Figure 13—Expression of cutting area and clearance between work gear and the cutting edge of hob tooth No. -22.

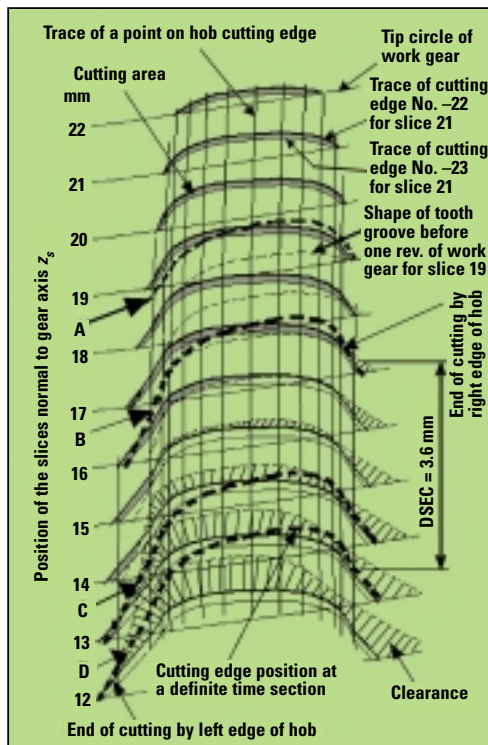

Figure 14—Expression of cutting area and clearance between work gear and cutting edge of hob tooth No. -22 (three-dimensional view). (DSEC: Distance of Single Edge Cutting.)

of the work gear, a bold curve shows the trace of the cutting edge of hob tooth No. -22, and the thin curve shows the trace of cutting edge No. -23 acting before cutting edge No. -22.

The inclined line below those traces is the tip circle of the work gear. The gray area where the trace of cutting edge No. -22 is deeper (upper in this figure) than any other trace, is cut by cutting edge No. -22. On the other hand, there is clearance (hatched area) between cutting edge No. -22 and the work gear's generated tooth flank at the area where the trace of cutting edge No. -22 is shallower than the other traces. In Figure 13(a), the whole range of the cutting edge inside the work gear's tip circle acts for cutting. At the lower  $z_s$  position, though (see Fig.13(b)), a large clearance exists near the middle and right cutting edges at a moment at which the hob's left cutting edge is acting.

Figure 14 shows the result of a simulation for tooth No. -22, which is observed from the same viewpoint as in Figure 12(a). Figures like Figure 13, but for different slice positions  $z_s$ , are arranged in a column. Actually, the position of the tooth groove on each slice is different in the circumferential direction because the sample work gear is helical. The cut groove on each slice is arranged here so that the middle position of the tooth groove on each slice is the same for easy understanding. The vertical line shows the trace of points on tooth No. -22's cutting edge, and the other types of curves have the same meaning as those in Figure 13.

The bold broken curves A, B, C and D show the cutting edge position at a definite time section. Cutting proceeds from curve A to D. Those cutting edge curves are inclined due to the hob set angle as shown in Figure 14. The hob's left edge therefore cuts each slice earlier than its right edge. The cutting edge exists as curve B when cutting by the hob's right edge finishes. Curve D exists at the end of cutting by the left edge. The left cutting edge therefore acts alone between the curves B and D. This distance BD in the work gear axis direction is called here the DSEC (Distance of Single Edge Cutting).

The movement of a generated chip on a hob tooth's rake surface depends on the acting position of the hob's cutting edge. Figure 15 shows a supposed movement of a generated chip on a rake surface at stages A, B, and C from a simulation (Ref. 11). At stage A, i.e. at the beginning of the generation of a chip, the chip flows toward the hob tooth root because the hob tip edge mainly cuts the work gear. The right edge finishes cutting at stage B and the direction of the chip movement changes. At stage C, the left edge cuts

alone and the already generated part of the chip moves toward the hob right edge.

At that stage, there is a large clearance between the hob's right cutting edge and the work gear's tooth flank. The chip could therefore intrude into the clearance. The chip could pass through the clearance if the chip is small enough and thin compared with the clearance. Otherwise, chip pinching and crushing could occur. In that case, the hob cutting edge could be damaged if the chip is thick and stiff. In case of a thin chip, part of the chip could scratch and/or be inlaid on the cut tooth flank of the manufactured gear.

It is possible to evaluate or understand the probability of chip crush between hob cutting edge and work gear tooth flank by utilizing graphical presentation for the results of the proposed analysis.

### Conclusion

Dry hobbing often causes failures of hob cutting edge or problems with the surface quality of manufactured gears' tooth flanks. Pinching and crushing of generated chips between hob cutting edge and work gear tooth flank is considered to be a major cause of those problems. In this report, a method to calculate and graphically express the trace of each hob cutting edge relative to a work gear is proposed. The following items are concluded:

- (1) Position, size and shape of clearance between hob cutting edge and work gear tooth flank during hobbing can be evaluated by the proposed simulation method.
- (2) It becomes easy to understand the state of chip generation by recognizing the size and shape of the cutting area by graphical expression of chip generation. Movement of the generated chip on the rake surface can be well imagined by calculating simultaneous cutting positions of the hob cutting edge.
- (3) The probability of chip crush can be evaluated by the size, thickness and movement of the generated chip, where the size and position of clearance are calculated from the proposed method.

The proposed simulation method is considered helpful in finding remedies for chipping of hob cutting edge and manufacturing of gears with coarse tooth flanks due to chip crush. ⚙

### References

1. Sakuragi, I., M. Kobayashi, N. Hakamata, M. Kawata, M. Sumi, and M. Yonekura. "Carbide Hobbing Technology for Automotive Gears," *Transactions of the Japan Society of Mechanical*

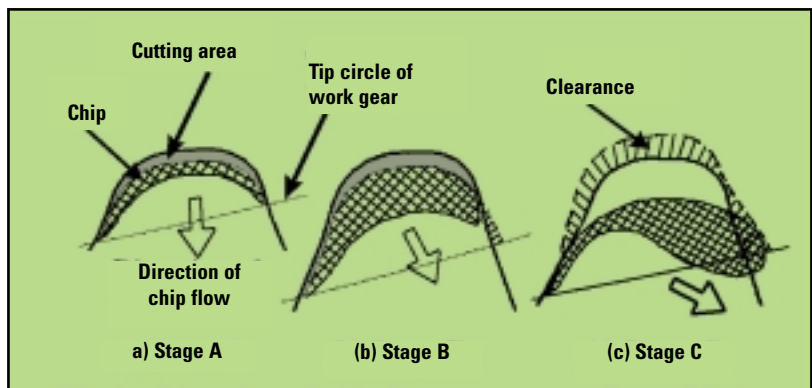

Figure 15—Direction of chip flow on rake surface of hob tooth at each cutting stage.

- Engineers (in Japanese), Series C, Vol. 67, No. 655, 2001, pp. 811–816.
2. Research report, Japan Gear Manufacturers Association, 2000.
3. Sakuragi, I., Y. Ochi, M. Kawata, M. Nishioka, M. Yonekura, and K. Tsumura. "Countermeasures of Inclusion of Chips on Gear Tooth Surface during High-speed Hobbing," *Proceedings of the Japan Society of Mechanical Engineers*, Vol. 01–1, 2001, pp. 147–148.
4. Sakuragi, I., M. Yonekura, M. Sumi, K. Tsumura, and J. Komatsu. "Fundamental Evaluation of Machinability of Gear Materials Aim at Carbide Hobbing," *Proceedings of the Japan Society of Mechanical Engineers*, Vol. 00–1, 2000, pp. 417–418.
5. Sakuragi, I., M. Yonekura, and M. Sumi. "Evaluation Method of Cutting Performance on High Speed Hobbing with the Carbide Hob," *Transactions of the Japan Society of Mechanical Engineers*, Series C, Vol. 67, No. 660, 2001, pp. 2725–2731.
6. Terashima, K., and T. Ueno. *Transactions of the Japan Society of Mechanical Engineers*, Series C, Vol. 43 No. 373, 1977, pp. 3535–3546.
7. Ainoura, M., M. Yonekura and K. Nagano. Fujikoshi technical report, Nachi-Fujikoshi Corp., Vol. 38-2, 1982, pp. 1–16.
8. Ueno, T., and M. Ainoura, *Proceedings of the Japan Society of Mechanical Engineers*, Vol. 9, 1959, pp. 15–20.
9. Hidaka, K., T. Ueno and K. Terashima. *Transactions of the Japan Society of Mechanical Engineers*, Series C, Vol. 45 No. 389, 1979, pp. 129–133.
10. Umezaki, Y., Y. Ariura, T. Ueno and S. Inoue. "The Corner Wear of a Hob Tooth" (1st Report, Cutting conditions of the teeth at which large corner wear occurs), *Transactions of the Japan Society of Mechanical Engineers*, Series C, Vol. 54, No. 501, 1988, pp. 1140–1143.
11. Asakura, S., N. Aoyama, S. Asakura, and K. Fukuta. "The Technology of High Performance Gear Cutting with Carbide Hob in Mass Production," *Proceedings of the Japan Society of Mechanical Engineers*, Vol. 98-1, 1998, pp. 579–580.
12. Sumi, M., A. Kubo and M. Komori. "Hob Cutting Simulation for Analysis of Chip Crush between Cutting Edge of Hob and Tooth Flank of Gear," *Transactions of the Japan Society of Mechanical Engineers*, Series C, Vol. 69, No.681, May 2003, pp. 1388–1395.
13. Sumi, M., A. Kubo and M. Komori. "Remedies for Cutting Edge Failure of Hob due to Chip Crush," *Transactions of the Japan Society of Mechanical Engineers*, Series C, Vol. 69, No.681, May 2003, pp. 1396–1403.

This paper was published in the May 2003 edition of *Transactions of the Japan Society of Mechanical Engineers*, Series C. It was published under the title "Hob Cutting Simulation for Analysis of Chip Crush between Cutting Edge of Hob and Tooth Flank of Gear."

The paper was also presented with its current title at the ASME/AGMA 2003 International Power Transmission and Gearing Conference, held Sept. 3–5, 2003, in Chicago, IL. It was also published in *Proceedings of the 2003 ASME Design Engineering Technical Conferences & Computers and Information in Engineering Conference*.

The paper is republished here with permission from JSME and ASME.

Tell Us What You Think . . .

E-mail [wrs@geartechnology.com](mailto:wrs@geartechnology.com) to

- Rate this article
- Request more information
- Contact the authors or organizations mentioned
- Make a suggestion

Or call (847) 437-6604 to talk to one of our editors!